

Aadva™ Lab Scanner 3 from GC

Manual

Simplicity
Accuracy
Productivity



Date of issue October 2023



Dear customer,

Congratulations on the purchase of your new **Aadva Lab Scanner 3** from GC!

This industry-leading digital product will support you in your laboratory for many years to come.

In case you have questions or would like to receive any assistance, please don't hesitate to contact your GC Local contact (1st line support) or our GC Europe Digital Service Team (2nd line Support)

Email: digitalservices.support@gc.dental

Office hours: 08:30h – 17:00h

We wish you much joy with your Aadva ALS 3 scanner!

CHANGES AND SERVICE

We reserve the right to implement product changes as part of continuous improvement and technical progress and to make changes to this documentation. You can find the current version of this documentation on our homepage: <https://digital.gceurope.com/products/aadvalabscan/>

On request we are also glad to send you a printed paper version of the documentation. Please send us an e mail to digitalservices.gce@gc.dental

BRANDS AND TRADEMARKS

Windows, .NET Framework and Visual C++ are registered trademarks of Microsoft Corporation.

FlyCapture and UpdatorGUI are registered trademarks of Point Grey Research, Inc.

exocad is a registered trademark of exocad GmbH, D-64293 Darmstadt.

Adesso Split and Artist/arTO are registered trademarks of K. Baumann, D-75210 Keltern.

SAM is a registered trademark of SAM Präzisionstechnik GmbH, D-82131 Gauting.

Artex is a registered trademark of Amann Girrbach AG, A-6842 Koblach.

Gamma is a registered trademark of Gamma medizinisch-wissenschaftliche Fortbildungs-GmbH, A-3400-Klosterneuburg.

PROTAR is a registered trademark of KaVo Dental GmbH, D-88400 Biberach/Riß.

Denar is a registered trademark of Whip Mix Corporation, Louisville, KY 40209, USA.

Triple Tray is a registered trademark of Premier Dental, Plymouth Meeting, PA 19462 U.S.A.

Where products belonging to other owners are referenced, we wish to point out that these are brands of the relevant owners that are protected by copyright laws.

Royalty-free icons and illustrations from the Flaticon.com, Fotolia.com, Freepik.com and Pixabay.com image agencies were used in this operating manual.

Table of contents

| | |
|---|-----------|
| 1. About | 4 |
| 1.1 Introduction | 4 |
| 1.2 Warnings | 5 |
| 2. For your safety | 6 |
| 2.1. Proper use | 6 |
| 2.2. General safety instructions | 7 |
| 2.3. Symbols on the device | 12 |
| 3. Scope of delivery | 13 |
| 4. Device components | 15 |
| 4.1. Front view | 15 |
| 4.2. Internal view | 15 |
| 4.3. View of the accessories | 17 |
| 4.4. Connections and type plate (rear view) | 18 |
| 5. Setup and commissioning of the scanner | 19 |
| 5.1. Choosing a workstation | 19 |
| 5.2. Unpacking the scanner | 19 |
| 5.3. Connecting the scanner | 20 |
| 5.4. Aadva Scan installation | 21 |
| 6. The object holder system | 27 |
| 6.1. Overview | 27 |
| 6.2. Matting the surface with 3D scan spray | 28 |
| 7. Positioning of a single jaw model | 29 |
| 7.1. Inserting a jaw model with a Multisplit mounting plate | 29 |
| 7.2. Inserting a jaw model with an adaptor plate | 30 |
| 7.3. Inserting a jaw model with an object holder | 32 |
| 7.4. Fastening gingiva, squeeze bites, scanbodies or wax-ups | 34 |
| 8. Positioning of non-articulated occlusion models | 35 |
| 8.1. Fastening an occlusion model with a rubber band | 35 |
| 8.2. Fastening of an occlusion model with an occlusion clamp | 36 |
| 9. Positioning of articulated occlusal models | 37 |
| 9.1. Positioning of an occlusal model with an articulator | 37 |
| 10. Positioning tooth stump models with the multiDie adaptor | 39 |
| 11. Positioning of a Triple Tray® impression | 41 |
| 12. Positioning objects (universal mode) | 44 |
| 12.1. Fastening objects on the flexible object holder | 44 |
| 12.2. Inserting the object holder | 46 |
| 12.3. Removing the object holder | 46 |
| 13. Positioning the calibration model | 47 |
| 14. Operating principle of the scanner | 48 |
| 14.1. Operation via gesture control | 48 |
| 14.2. Die projections | 49 |
| 14.2.1. Die projections after the 2D scan | 49 |
| 14.2.2. Die projections during the scanning process | 50 |
| 14.3. Switching between LR and HR mode | 50 |
| 15. Device maintenance | 50 |
| 16. Faults and repairs | 51 |
| 17. Environmentally-friendly disposal | 52 |
| 17.1. Disposal of the packaging | 52 |
| 17.2. Disposal of the device | 52 |
| 18. Technical specifications | 53 |
| 19. Glossary | 54 |

1. About

Please read through this operating manual carefully.

GC accepts no liability for damages due to failure to comply with the operating manual.

1.1 Introduction

ALS 3 combines unique scan features with robust scanning hardware that will simplify your daily lab work.

ADVANTAGES

- /// Constant & reliable accuracy
- /// Full color scanning
- /// Speed and quality
- /// 2 x 3.2 Mpx camera
- /// Full exocad® integration
- /// Open files (STL and PLY)
- /// Complete jaw scanned in 12 sec
- /// Gesture control
- /// 4 µm accuracy according to ISO 12836
- /// Automatic Z-height adjustments

TECHNICAL DATA

- /// Measurement field (X × Y × Z) 85,2 × 58,1 × 82 mm
- /// 2 x 3.2 Mpx camera
- /// Blue light LED sensor technology
- /// Stripe light triangulation
- /// Monochrome texture scan
- /// Color texture scan
- /// Fully automated Z-axis
- /// Articulator scan
- /// multiDie scan
- /// Triple Tray® scan
- /// Impression scan
- /// Twin Tray scan
- /// Blue light diffuser

Figures showing equipment and screenshots from the software are used for illustration purposes. The screenshots show realistic examples but do not contain actual data. In this manual the numbers are given according to the decimal system with decimal places. Units of measurement comply with the international system of units (SI). Further information as well as measurement converters can be found on the Internet.

| Measurement | Unit | Abbreviation |
|----------------------|--|---|
| Mass/weight | Kilogram | kg |
| | Gram | g |
| Length | Meter | m |
| | Centimeter | cm |
| | Millimeter | mm |
| | Micrometer | μ |
| Angle | Degree | ° |
| Time | Hour | h |
| | Minute | m |
| | Second | s |
| Electrical power | Watt | W |
| Electrical voltage | Volt | V |
| | Alternating current | AC |
| Electrical frequency | Hertz | Hz |
| | Gigahertz | Ghz |
| Electrical current | Ampere | A |
| Protection class | International Protection | IP |
| | | 1 st digit: solids protection; 2 nd digit: fluids protection |
| Temperature | Degree Celsius | ° |
| Memory (PC) | Random-Access Memory | RAM |
| Data volume | Megabyte | MB |
| | Gigabyte | GB |
| CAD data format | Polygon file format | PLY |
| | Standard Triangulation Language | STL |
| | American Standard Code for Information Interchange | ASCII |
| | Mesh | MSH |
| | Point Cloud Measurement | PCM |
| Picture element | Pixel | Px (monitor) |
| | | dpi (print) |
| | Megapixel | Mpx |

1.2 Warnings

Warnings provide information on how damage to objects and injury to persons can occur and give instructions on how to avoid risks. Warnings are categorized into four levels depending on the severity of the possible consequences.



NOTE

This combination of signal word and symbol warns you about possible material damage that might occur if the instructions are not followed correctly.



CAUTION

This combination of signal word and symbol warns you about possible minor injuries that might occur if the instructions are not followed correctly.



WARNING

This combination of signal word and symbol warns you about severe to lethal injuries that might occur if the instructions are not followed correctly.



DANGER

This combination of signal word and symbol warns you of dangerous situations which could lead directly to death or severe injuries.

2. For your safety

2.1. Proper use

USE IN DENTAL TECHNOLOGY

The proper use of the ALS 3 is the optical three-dimensional measurement of human jaw models. The scanners can be used in the field of orthodontics and prosthetics for all kinds of reconstructions, as well as for archiving purposes.

Jaw models in occlusal relationship can be scanned with reference to cephalic presentation, as well as dental registrations (bite registrations) and dental casts (wax-up), and also reference bodies (scan bodies) screw-retained in the model.

USE AS A UNIVERSAL SCANNER

The proper use of the ALS 3 scanner is the optical three-dimensional measurement of objects with a maximum size of 85,2 × 58,1 × 82 mm (XYZ). The maximum weight of the objects must not exceed 0.938 kg. The scanners can be used for the production of, for example, tools, jewelry or toys as well as to test the accuracy of replicas.

MATERIAL CHARACTERISTICS

The ALS 3 scan materials with a dry/ matted, opaque surface of white, saffron, gold, blue, beige, yellow and pink color. Reflective or dark surfaces can be scanned if they are previously treated with 3D scan spray. Moveable parts of the models must be able to be immobilized, so that they do not change their position during scanning.

IMPROPER USE

The ALS 3 is not designed to scan models made of transparent materials, models of non-dimensionally stable or unstable materials or living organisms.

The ALS 3 is not suitable for use in an environment heavily burdened by emissions (e.g. dust or paint). Their use in a private environment is also excluded.

GC strongly advises to avoid any other than the proper use. GC assumes no liability for damages due to an improper use of the scanner and/or non-observance of the safety instructions indicated in these operating instructions.

2.2. General safety instructions

USER QUALIFICATION

Users who set up, commission or operate a GC scanner require special knowledge for the safe operation of the scanner. This knowledge can be acquired by means of the following measures:

- Read and follow these operating instructions, in particular the instructions concerning setup, commissioning and cleaning of the scanner.
- Participate in an education or training course.
- Comply with local laws, regulations, occupational safety and accident prevention rules concerning your scanner's workplace.
- Make sure that all devices and cables pass the periodic safety checks for electrical appliances. Replace damaged devices and cables immediately. Make sure that the technical specifications of power cables are adequate.

CONSTRUCTIVE PROTECTIVE MEASURES

The scanner has been developed and manufactured in compliance with the applicable safety standards and with the greatest possible care to ensure safe operation and to protect the user against injuries.

A fuse to protect the device from overvoltage is integrated into the device.

PROTECTION AGAINST INJURIES

Despite the protective measures included in the design, some residual risks that might lead to injuries cannot be excluded. In this section you will learn what measures you can take to protect yourself and other people.

Electric shock and short circuit



WARNING

Risk of injury due to electric shock

Fire hazard due to short circuit

A technical defect of the cable or of individual components of the scanner can cause an electric shock or a short circuit. This can result in a fire.

- Make sure that no electrical equipment can come into contact with water/moisture. Should this however happen at some time, disconnect the power plug immediately. Dry the affected parts with a soft microfiber cloth.
- Do not work with defective devices or cables under any circumstances.
- Operate electrical equipment only at the recommended operating temperatures.
- Only use the supplied cable or the corresponding spare parts.
- If electrical devices are not used over a longer period, such as overnight, turn them off and disconnect the power plug from the socket.

Magnetic fields



WARNING

Health hazard due to magnetic fields

The scanner and its accessories include magnetic components. Magnetic fields can be health-damaging.

- Persons with implants, in particular heart pacemakers, may only operate the scanner and its accessories with express medical permission.

Stripe light



WARNING

Health hazard due to stripe light

The scanner works with stripe light. Constant visual contact with stripe light can trigger epileptic seizures, migraine or similar conditions.

- Individuals suffering from such conditions should cover the scanner during operation.

Falling



CAUTION

Risk of falling due to packaging materials

The scanner is extensively packaged for protection against transport damages. The packaging can be an obstacle during setup and can cause falls.

- Do not leave packaging materials lying on the ground.
- Before transporting, move all obstacles out of the way.

Carrying



CAUTION

Risk of injury due to incorrect carrying

Due to its size and weight, we recommend that two people should unpack and set up the scanner. In particular, shorter individuals can be injured if they lift or carry the scanner by themselves without any help.

- Two people should lift the scanner out of its packaging.
- Two people should carry the scanner.
- To transport the scanner, always grasp it by the bottom corners.

Crushing



CAUTION

Risk of injury due to the mechanical parts of the scanner

You can get crushed by the mechanical parts of the scanner.

- Only put your hands inside the scanner when the axes have stopped. Should the axes not stop at the end of a scanning process, turn off the scanner and disconnect the power plug.

Entanglement



CAUTION

Injury due to entanglement of clothing, jewelry or hair

Loose clothing, jewelry or long hair can get entangled in the mechanical parts of the scanner. Due to motion, objects and hair can get entangled inside the scanner. This can lead to injury.

- Do not wear any loose garments such as shawls and ties, or jewelry like long necklaces, at the scanner's workplace.
- Comb your hair into a firm pigtail, for example.
- However, should a piece of clothing, hair or jewelry get entangled among the moving parts of the device, turn the scanner off immediately. Disconnect the power plug before removing the entangled part.

PROTECTION AGAINST MATERIAL DAMAGES

Despite the protective measures included in the design, some residual risks that might lead to material damages (loss of data or damage to devices) cannot be excluded. In this section you will learn what measures can be taken against material damages.

Optics/Electronics



NOTE

Damage to optical and electronic components due to touching, humidity, dirt and cleaning

The optical and electronic components in the interior of the scanner are highly sensitive. Any touch, as well as dirt, moisture and cleaning agents can damage them.

- Do not touch any optical and electronic components,
- Protect the optical and electronic components against soiling by covering the scanner.
- Never use the 3D scan spray inside the scanner.
- If the optical or electronic components have to be cleaned, do not do it yourself. Please contact GC.

Carrying



NOTE

Damage to the scanner due to incorrect carrying

The front upper corners are not suitable to be used as carrying handles. If you carry the scanner by the front upper corners, they can come off and the scanner will fall and get damaged. If you reach into the front upper corners, you can damage sensitive components, especially the camera and the sensor.

- To transport the scanner, always grasp it by the bottom corners, never by the front upper corners.

Cleaning agents



NOTE

Damage to surfaces due to unsuitable cleaning agents

Paper towels, coarse cotton cloth, detergents, polishing paste, etc. leave scratches on the sensitive surfaces.

- Only use the recommended materials for cleaning.

Moisture



NOTE

Material damages due to moisture

Constant contact with moisture can damage sensitive materials.

- Only operate the scanner at a dry workplace.
- Avoid any contact with water/moisture. Should this however happen at some time, disconnect the power plug immediately. Immediately wipe off any water/moisture using a soft microfiber cloth.

Climate



NOTE

Measuring errors due to unsuitable climatic conditions

The scanner is designed solely for use inside dry, closed rooms. Precise measurement results are only achieved by the scanner under suitable climatic conditions. Too much heat causes measurement errors and overheating of the scanner. Overheating can permanently damage the scanner.

- Only operate the scanner at temperatures of 18°C - 30°C.
- Only operate the scanner in low humidity conditions.
- Avoid direct sun exposure at the workplace.
- Reduce cold, heat and high humidity, e.g. through the use of air conditioners or sun protection.

Reflections



NOTE

Measuring errors due to reflections on the measured object

Strong extraneous light leads to unwanted reflections on the measured object. This affects the accuracy of the measurements.

- Select a workplace away from a window or not affected by high levels of artificial lighting.
- Cover the opening during the scanning process, e.g. with light-tight foil/dust-cover.

Vibration



NOTE

Measuring errors due to vibrations

The surface on which the scanner is placed must not vibrate. Vibration will cause inaccurate measurement results.

- Place the scanner on a sturdy, stable base able to support at least twice the weight of the scanner, i.e. 2 x 23 kg.
- Stabilize the base by means of a strutted under frame or by attaching it to a stable wall.

Calibration



NOTE

Inaccurate measurements due to failure to calibrate or use of a damaged calibration model

The measuring accuracy of the scanner is only guaranteed if the scanner is calibrated. This operation requires the use of a calibration model and the associated default values.

The calibration model can be mechanically damaged. This can only be tolerated in the border area.

- Perform the calibration of the scanner after commissioning, after transporting it and whenever the software asks you to do so during operation.
- Only start the procedure when the values registered in the software match the values of the calibration model.
- Check whether the calibration model is damaged at a central location.
- Only use the calibration model if it is in perfect condition.

Model fastening



NOTE

Damage to the scanner and the models due to missing or incorrect fastening

Due to the motion of the axes inside the scanner, unsecured or incorrectly secured models will fall down during the scanning process.

- Do not place any objects on top of or inside the scanner.
- Never place unfastened models inside the scanner.
- Only use the included object holder or approved accessories to fasten models.
- When fastening occlusal models with rubber bands, only use stable, unused rubber bands. Thin or porous rubber bands can tear.
- Always fasten models on the flexible object holder and the multiDie adaptor using adhesive pads made of modeling clay.
- Only place stump models prepared with metal pins inside the multiDie adaptor.
- However, should a model still fall down, turn off the scanner immediately. Then remove the model or all broken pieces from the interior of the scanner.

Adhesive materials



NOTE

Damages to models due to unsuitable adhesive materials

Models, object holders and the scanner get soiled or are even damaged through the use of adhesive tape, instant glue or similar products.

- Only fasten models using adhesive pads made of modeling clay.

Articulators



NOTE

Damages to the scanner and models due to incorrectly positioned articulators

Articulators are not to be fastened inside the scanner. This is possible because articulators can be scanned with reduced axis motion.

- Only place an articulator inside the scanner when the software asks you to do so.
- Always place an articulator with the front side first inside the scanner.
- Always place an articulator with all legs resting on the system plate.
- Remove an articulator immediately when the software asks you to do so.
- However, should an articulator still fall down, turn off the scanner immediately. Then remove the articulator or all broken pieces from the interior of the scanner.

USB cable



NOTE

Data loss due to a too long USB cable

The transfer of data between the scanner and the PC is affected by the length of the USB 3 cable.

- Only use the supplied USB 3 cable or an original spare part with the corresponding length (max. 2 meters).

Magnetic fields



NOTE

Data loss due to magnetic fields

The scanner and its accessories include magnetic components. Metal-containing technical devices and data carriers, e.g. credit cards, can be impaired in their function or even permanently damaged through contact with magnets.

- Make sure there is an adequate distance between metal-containing technical devices/data carriers and the magnet.

RESPONSE IN CASE OF A DEFECT

You must not work with a defective system. Damage to the scanner, its accessories or a faulty function have occurred with high probability if:

- parts have been visibly damaged
- one or more of the moving axes continue to rotate or rotate in an uncontrolled way
- the calibration procedure fails
- measuring errors occur despite performing all work steps
- the software displays an error message.

PROBLEM SOLVING GUIDELINES:

- Follow the instruction in an error message.
- Check the connections. If applicable, replace the USB slots.
- End the software, switch off the scanner and the PC and restart the system.
- Check whether the software is installed correctly.
- Check the calibration data.
- Follow the instruction for device maintenance.
- Update your system. Check whether all important Windows updates have been installed.
- Ensure that your computer is free of viruses and malware.
- Allow the execution of Aadva Scan in your virus protection software.
- If none of these measures solve the problem, repeat with another computer to exclude a computer fault.

If problem persists please contact your local sales representative (1st line support) or GC scanner support via digitalservices.support@gc.dental (2nd line support).

2.3. Symbols on the device

WARNINGS



Warning against hand injuries

If a body part enters the scanner opening, there is a risk of crushing.
Always exercise care when reaching into the scanner to place the object holder.



Electrical voltage warning

This sign warns of electrical voltage inside the scanner.
The rear cover of the scanner may only be removed by skilled personnel if the mains plug has been disconnected from the mains.



Do not touch

This symbol refers to the calibrated optical system.
This must never be touched or cleaned as it could be damaged in the process.

OTHER



CE label

The CE label on the type plate documents that the European directives that are applicable to the device were complied with at the time of issue of the CE certificate.

EMC labelling

EN 55011 Class A

The electromagnetic compatibility of the device was checked for compliance with the limit values according to the European standard and the measuring methods for radio interference of industrial, scientific and medical high frequency devices. Labelling as "Class A" states that the device meets the standard for commercial applications.



Fuse

Symbol for an overcurrent protection device, installed in a mains connection, suitable for AC voltage 100 - 240 Volt and a frequency of 50/60 Hertz.



USB

Symbol for a USB connection, also for a camera connection.



Protective grounding

Symbol for connection to an external conductor to protect against electric shock in the event of a fault or connection of protective grounding (mass).



On/Off switch

Symbol for a switch to turn the device on and off.

3. Scope of delivery

The scope of delivery includes the following components:

ALS 3

1 Scanner

- Blue light LED
- 2 x 3.2 Mpx camera

1 power cable

~~1 USB cable~~

1 Object holder with screw

1 3D calibration model

1 USB data carrier

- Calibration data
- PDF with download link to technical manual and Aadva Scan software.

PACKAGING

The packaging consists of the following components:

- top insert with foam protection
- carton accessory box
- bag (protective cover for the scanner)
- carton cable box
- foam insert

OPTIONAL ACCESSORIES

In the case of ALS 3, all components are already included in the standard scope of delivery. The exception being articulators (not an accessory) as well as adaptor plates for articulators (chargeable accessory).

Please contact your local GC office to order additional accessories.

| Article number | Product Name |
|-----------------|---|
| 70001833 | multiDie adaptor with adhesive pads |
| 70001834 | Triple Tray Impression holder |
| 70001835 | 3D calibration model |
| 70001836 | Flexible object holder and 4-teeth bar for Twin Tray impression scans, with adhesive pads |
| 70001843 | Dust cover ALS 3 |
| 70001837 | Adaptor plate AdessoSplit to Gamma |
| 70001838 | Adaptor plate AdessoSplit to SAM |
| 70001839 | Adaptor plate AdessoSplit to KaVo Protar |
| 70001840 | Adaptor plate AdessoSplit to Whip Mix |
| 70001841 | Occlusion clip for upper and lower jaw |

For safety reasons, please use only the replacement or additional items mentioned here. For parts that are not listed as replacement items, e.g. cables, please replace them with commercially available products with the same technical specifications.

PCs must meet the technical specifications.

SUPPORTED ARTICULATOR SYSTEMS

Articulators are available at specialist dental dealers, but cannot be purchased from GC as accessories for the scanner. All conventional articulators can be used for vestibular scans with articulated occlusion models. Condyle-related measurements are possible with the articulators of the following manufacturers:

- AMANN GIRRBACH Artex®
- Baumann Dental Artist/arTO®
- SAM® AXIOSPLIT®
- GAMMA® Reference
- Whip Mix Denar®
- KaVo PROTAR®

Other articulators can be used for mean value measurements.

4. Device components

4.1. Front view



4.2. Internal view

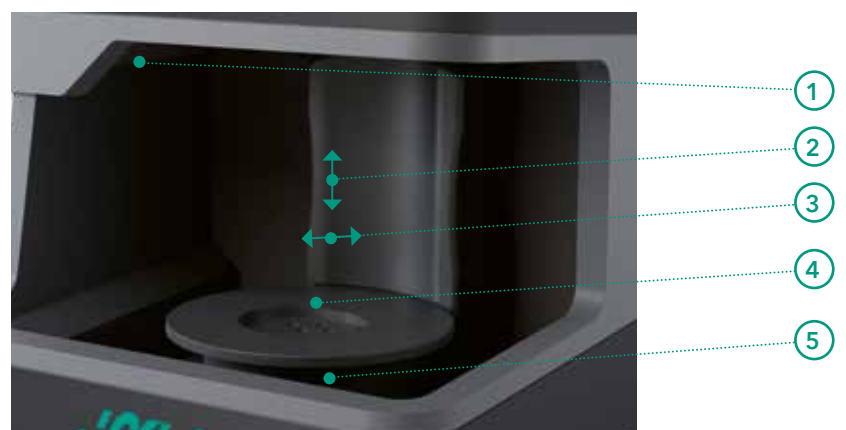

1. Optics (cameras and 3D sensor)
2. Z-axis (electromotive up and downwards movement 0 - 30 mm)
3. Swivel axis (electromotive lateral movement 0 - 45°)
4. System plate with Adesso Multisplit base plate
5. Rotary axis (electromotive rotation up to 315°)

DETAILED VIEW OF THE SYSTEM PLATE

- 1. Turntable with non-slip rubber mat for the placement of articulators
- 2. Adesso® Multisplit base plate for mounting object holders, adaptor plates and Multisplit mounting plates

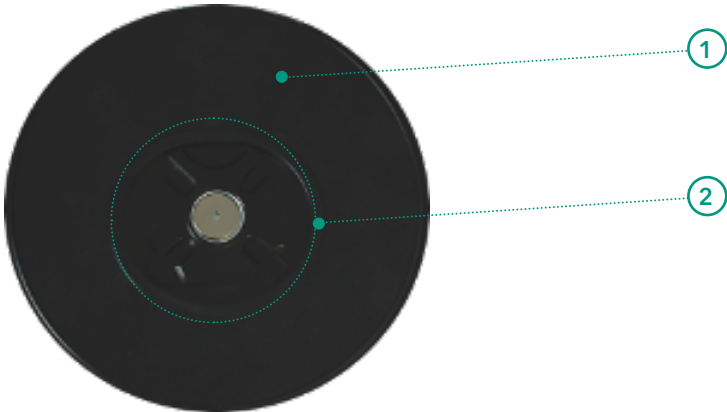

DETAILED VIEW OF CAMERA, SENSOR AND LED

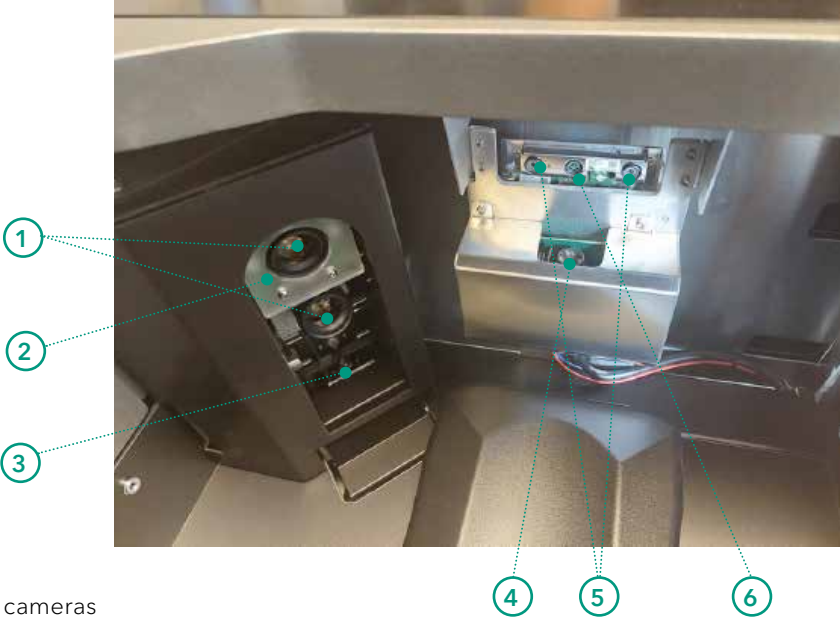

- 1. 3.2 Mpx cameras
- 2. Blue LED diffuser
- 3. Scanning projector
- 4. Gesture control projector
- 5. 1 Mpx cameras
- 6. Infrared sensor

4.3. View of the accessories



Object holder with knurled screw



Flexible object holder



multiDie adaptor, fixing with adhesive pads



4-teeth bar



Triple Tray Impression Holder



Calibration model
(Example image)



Power cable



USB cable



Adhesive glue pads, extra-strong
(Example image)



Dust cover



Data carrier
(Example image)

4.4. Connections and type plate (rear view)



1. ON/OFF switch
2. Functional grounding
3. USB 3.0 connection for device control and camera
4. Mains connection with fuse

Type plate

The type plate with technical information such as serial number of the device, place and date of manufacture is located on the rear.

The serial number of the 3D sensor is given on a separate label.



5. Setup and commissioning of the scanner

5.1. Choosing a workstation

OBSERVE THE SAFETY INSTRUCTIONS!

- When choosing a workstation, please note that the ALS 3 is an EMC Class A devices suitable for use in a commercial environment.
- Choose a stable work desk that is big enough to allow the scanner to be connected to a PC. The weight of the scanner is 23 kg and its setup dimensions are 455 × 430 × 435 mm (W x H x D).
- Ensure easy access to the rear as this is where the ON/OFF switch is located.
- Ensure that there are enough and sufficiently fused mains sockets for all the devices. After consultation with an electrician, you can use an approved extension cable, a multiple power socket and a socket adaptor (additional electrical devices not included in the scope of delivery).



5.2. Unpacking the scanner

OBSERVE THE SAFETY INSTRUCTIONS!

The scanner is delivered in a foldable carton box. The carton box is equipped with an impact and tilt indicator (outside) and clad with a foam transport protection (inside).

Keep the packaging for possible transport or return. The original packaging is precisely adapted to the scanner and thus offers the best protection against transport damage.

- Check the outer packaging for visible damage immediately on receipt.
- If an indicator indicates a careless storage or even any shipping irregularities or if damage is evident on the packaging, please inform the delivery company and GC. Follow the instructions provided by the delivery company and GC before continuing to unpack the device.
- Transport the scanner in the packaging as close to the workstation as possible.
- Remove the accessory case and place it aside. The accessories may be on top or below the scanner.
- Remove the foam board.

Due to the dimensions and weight GC recommends carrying by two persons.

Never hold it by the front upper corners or inner parts because sensitive technical components are placed there.

The protective bag prevents incorrect gripping.



- Position yourself with a second person to the right and left of the scanner.
- Place one hand each under the front and rear corner of the scanner.
- Lift the scanner simultaneously.
- When carrying, incline the scanner slightly backwards.

Setting the scanner down

- Set the scanner down carefully and in a straight position at the place of installation.
- Remove the protective bag.
- Immediately check the scanner and the accessories for completeness and any visible damage.

If the scope of delivery is not complete or if one of the supplied parts shows visible damage, contact your GC digital specialist. Follow the instructions provided by GC before continuing with the setup.

5.3. Connecting the scanner

The scanner requires a mains connection and a PC connection. The scanner does not work without a software.

The connections are located on the rear of the scanner.



- Connect the type B plug of the USB 3.0 cable to the USB 3.0 port of the scanner.
- Connect the device plug of the power cable to the corresponding mains socket on the scanner.

CABLE CONNECTIONS OF THE SCANNER

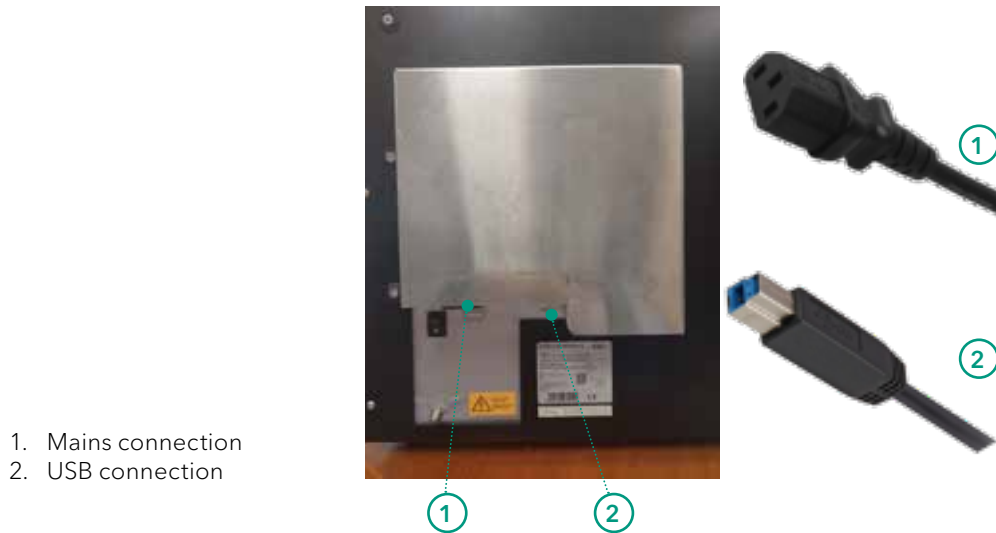

- Connect the mains plug of the power cable to the mains. It is not necessary to use an adaptor to adjust the voltage as an AC-DC device is integrated in the scanner.



- Connect the flat type A plug of the USB 3.0 cable to a free USB 3.0 port of the PC.

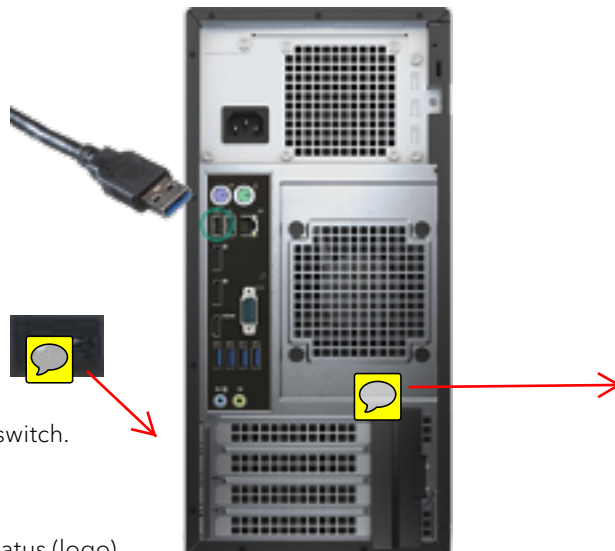

- ✓ The scanner is operational.
Switch on the scanner using the power switch.
- ✓ The power switch is in position I.
- ✓ The touchscreen displays the starting status (logo).

5.4. Aadva Scan installation

The installation of the software consists of two steps: executing the setup and loading the calibration data.

- Insert data carrier to open the PDF with links to download the latest Aadva Scan software from the GC Europe website.
- // After a short waiting period the content of the installation data carrier will be displayed automatically. If this is not the case, open the appropriate drive in Windows Explorer and then the installation folder.
 - Open the PDF with links to download the latest Aadva Scan software from the GC Europe website.
 - Double-click the executable EXE file.
- // Windows User Account Control will ask you if the software should be allowed to make changes to your computer.
 - Click **Yes**.
- // Setup will ask you to choose a language for the setup dialogues. The suggested language is the one selected in the operating system.

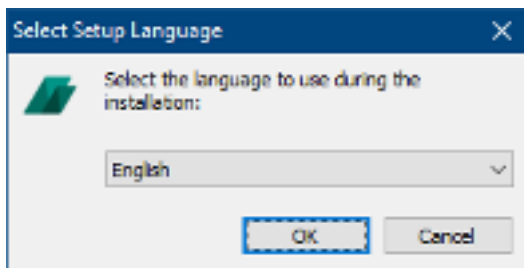

- To choose a different language for the setup, simply select it from the dropdown list. The following are available: German, English, Spanish, French, Italian, Czech, Portuguese, Romanian, Turkish, Greek, Russian, Japanese, Korean, Chinese (traditional and simplified).
- Click **OK**. Please note that you cannot revert back to the choice of language during setup.
- // The welcome screen then pops up with information about the setup process and on the version.

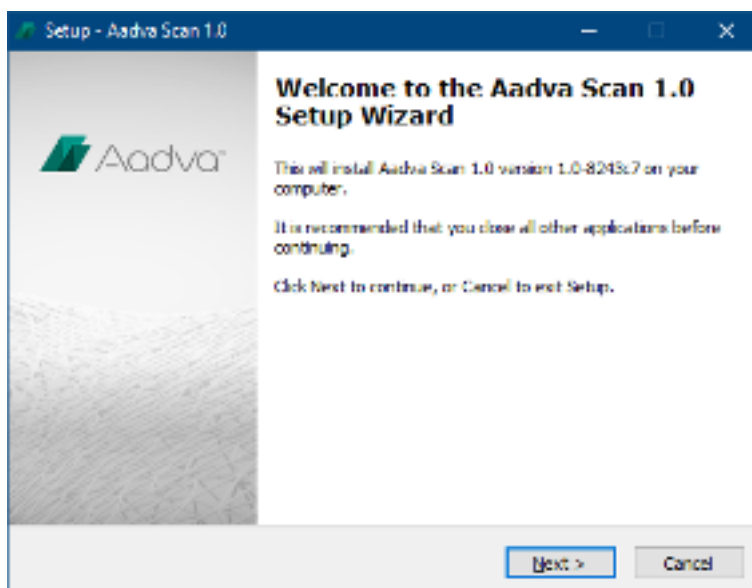

- Click **Next**.

- Setup will ask you to choose a destination folder for the installation.

Target folder = Installation folder

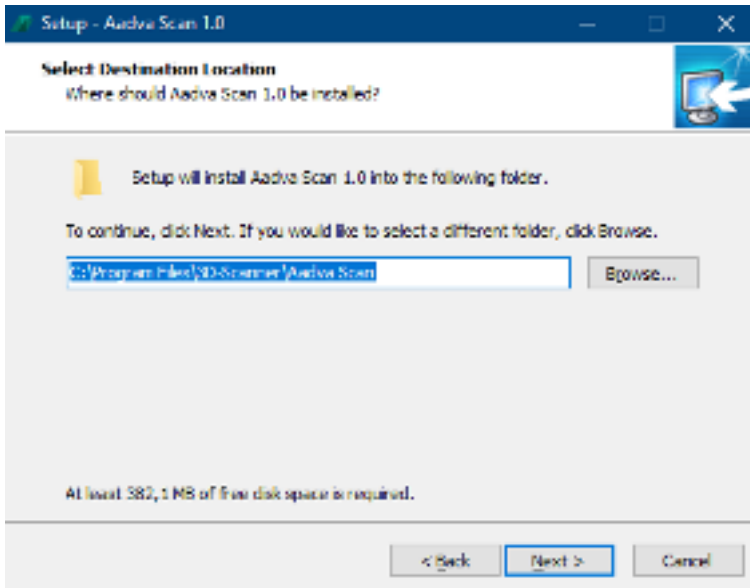

- Accept the suggested destination folder. If the suggested folder is not desired, then you can change the name or click on Browse and select a different local folder.
- Click on **Next**.

- Setup will ask you to choose a start menu folder.

Start menu folder = App overview

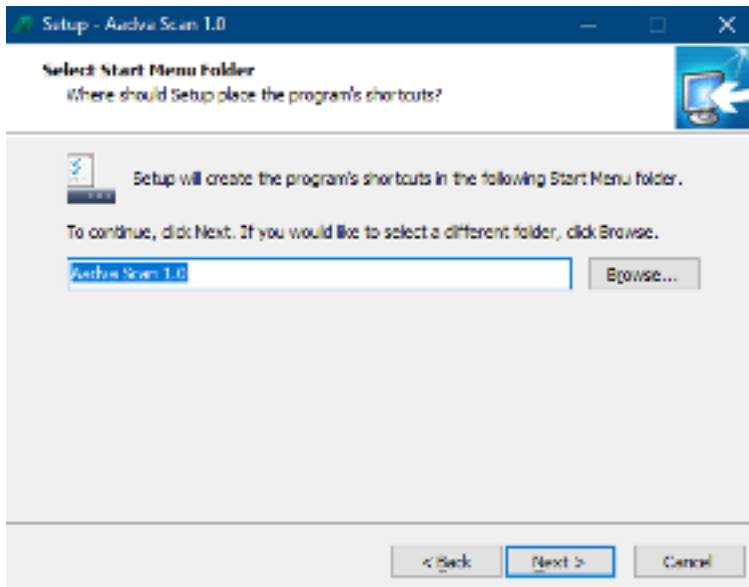

- Accept the suggested Start menu folder. If the suggested folder is not desired, then you can change the name or click on **Browse** and select a different local folder.
- Click on **Next**.

- Setup will ask you whether you wish to create a desktop shortcut to start the software.

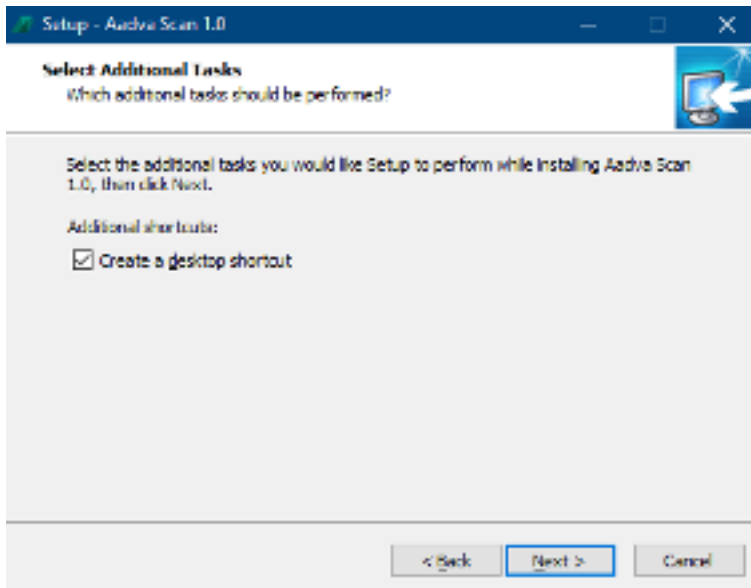

- Click on **Next**.

➤ The **Ready to Install** window pops up. All selected settings are displayed.

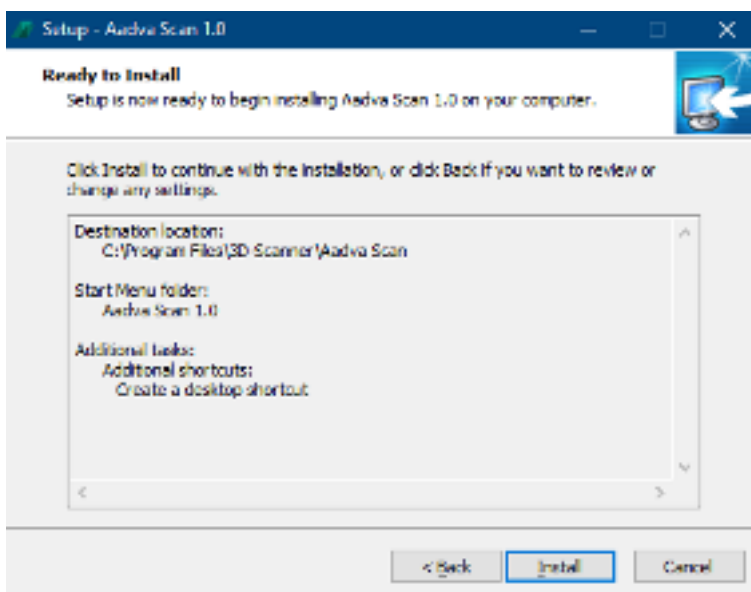

- Check the settings (destination folder, Start menu folder and desktop shortcut). To correct any of the displayed settings, click on **Back**.
- To start the installation with the displayed settings, click on **Install**.

➤ The installation process starts, and its progress is displayed on the screen. In addition to Aadva Scan, device drivers, the camera's software as well as any missing Windows components will be installed.

➤ The final window for finishing the setup is displayed. You will be asked to decide whether the computer should be restarted immediately or later. GC recommends activating the option for immediate restart.

- Click **Finish**.

➤ Setup is completed. Depending on your choice, the computer will restart. A new shortcut is now available on the desktop and the Start menu contains a new software icon.

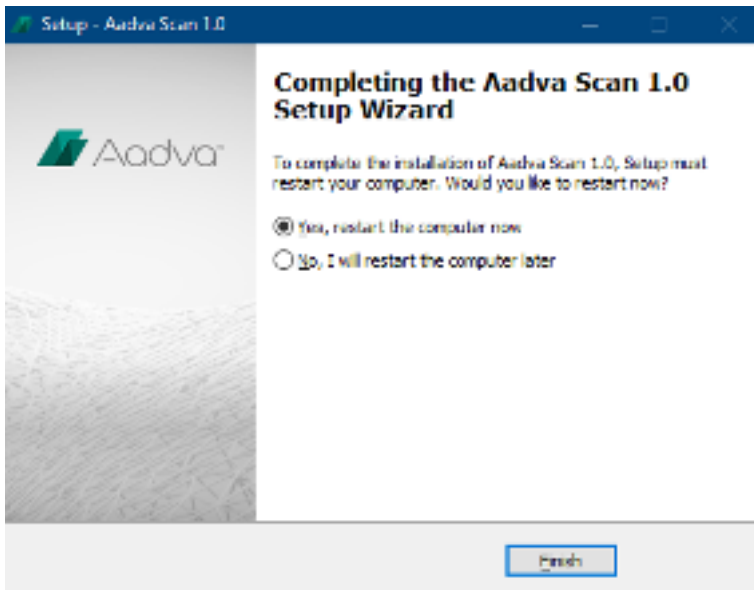

LOADING OF CALIBRATION DATA

- Start Aadva Scan double-clicking the desktop shortcut or by selecting the Start menu item.
- ▀ When starting the software for the first time, you will receive a message stating that the calibration data is missing in the Windows folder:
C:\ProgramData\3D-Scanner\DeviceCharacteristics\Sensors.

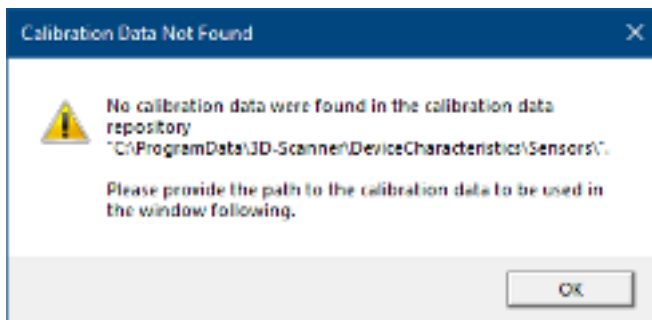

- Click **OK**.
- ▀ You will be asked to indicate the path to the calibration data to be copied into the Windows folder mentioned above.
- ▀ If the path is not found automatically, click on ... and select the folder \SO-202... on the installation data carrier. The full name of the folder is always different, as it is unique for every device.



NOTE

Measuring errors due to incorrect calibration data

The name of the SO folder on the data carrier must match the serial number of the 3D sensor on the type plate or the SO label.

- Compare the SO numbers on the scanner and the data carrier. You must not use calibration data if the numbers do not match.
- Contact the GC support via digitalservices.gce@gc.dental.

- Click **OK**.

- // The data will be copied into the protected Windows folder
 C:\ProgramData\3D-Scanner\DeviceCharacteristics\Sensors\SO-202....

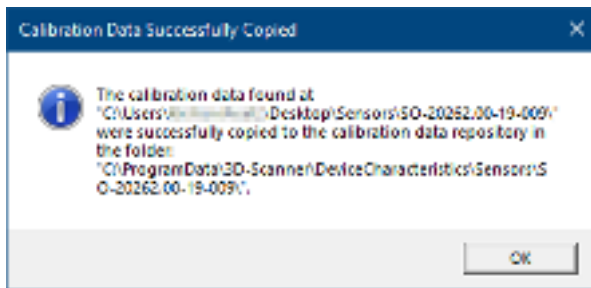

- // As of now, the calibration data will be found when starting the software. The software will only start if the scanner is connected and switched on.

- At the first start Aadva Scan requires the Activation ID for your GC license.



- Enter the GC license ID and click **OK**.

- // The license is saved. From now on you can use Aadva Scan for this specific scanner according to your license agreement with GC.

If you want to change your GC license, you have to reset the Activation ID via the “Miscellaneous” menu of Aadva Scan first. You can do the same in preparation for scanning with another ALS 3 scanner.

- At the first **start the calibration** of your scanner is mandatory. Otherwise Aadva Scan will be closed.
- To start calibration, click on **Start calibration** in the message box. You can click on the “Miscellaneous” icon and then on **Calibration** at any time during operation.

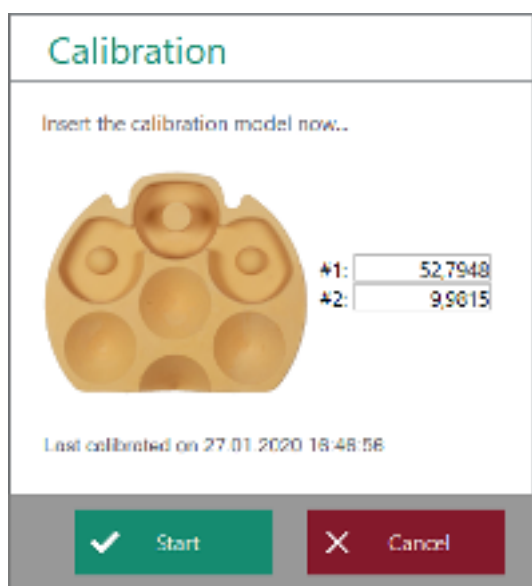

- Fixate the calibration model on the object holder.
- Position the calibration model in the scanner.

- Check whether the values in the fields **#1** and **#2** correlate with the values on the back of the calibration model. Adopt the values of the calibration model.
 - Click on **Start**.
 - After the start, you can no longer interrupt the process. The scanner is calibrated. A message will inform you about this process:
- /// After successful completion of calibration, the message **3D calibration has been executed successfully** will be displayed:

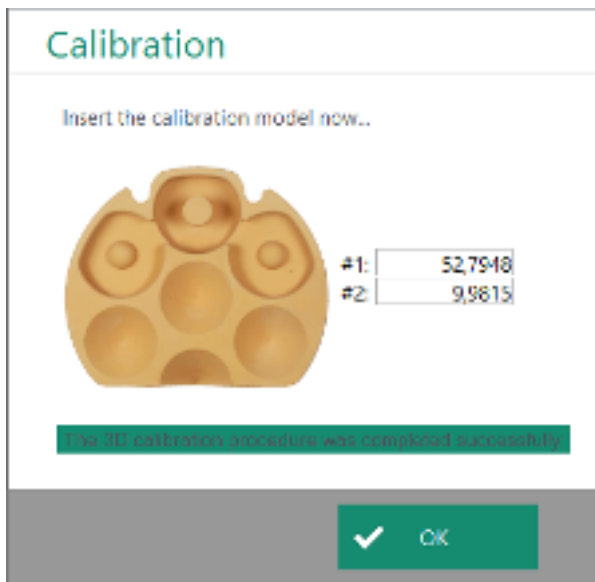

- Click **OK**.
- /// The dialog closes. You can now start scanning.

6. The object holder system

6.1. Overview

OBSERVE THE SAFETY INSTRUCTIONS!

The extensive object holder system of the ALS 3 allows you to securely fasten and insert jaw models, partial models, tooth stump models, Triple Tray impressions and occlusion models.

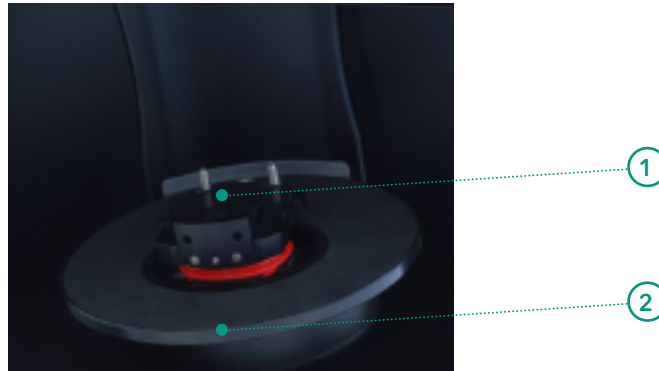

1. Object holder: in this case the model with knurled screw for single jaw models
2. Base plate with non-slip rubber mat and Multisplit base for object holder, adaptor plates and Multisplit mounting plates

MULTISPLIT BASE PLATE

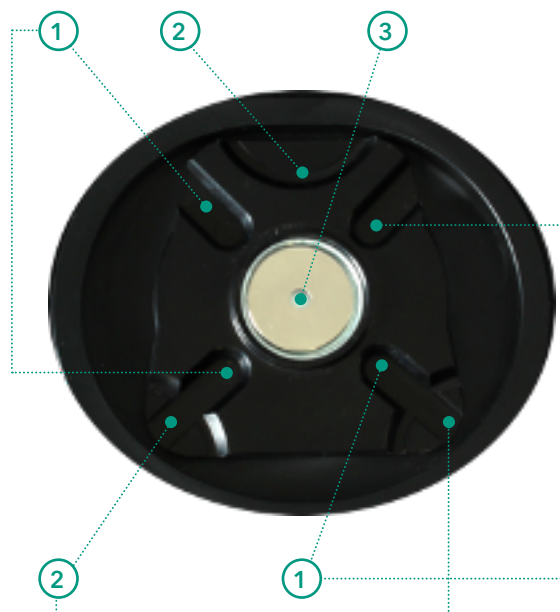

1. Contact points for object holders and adaptor plates ("Ovals")
2. Contact points for Multisplit mounting plates ("Corners")
3. Magnetic adhesive disk for mounting object holders, adaptor plates and Multisplit mounting plates

6.2. Matting the surface with 3D scan spray

Reflective or dark surfaces must be matted with 3D scan spray before being scanned.

GC recommends that only products with extra-fine grain size and suitability for dental technology be used.

- Follow the instructions of the manufacturer regarding application, safety and material compatibility.
- If the 3D scan spray has to be sprayed in the work area, cover the scanner previously.
This way, you protect the sensitive optical and the electronic components from damaging dusts.
Never spray into the inside of the scanner.
- Fasten the model or object to the object holder before spraying.
- Spray according to the instructions as targeted as possible onto the model or object.
- When inserting, make sure not to touch the spray layer.
- After scanning, remove the spray residue from the object holder and model or object.
Follow the instructions of the manufacturer for this as well.

7. Positioning of a single jaw model

You have several options for fastening single jaw models.

- Inserting a jaw model with a Multisplit mounting plate
- Inserting a jaw model with an adaptor plate
- Inserting a jaw model with an object holder

7.1. Inserting a jaw model with a Multisplit mounting plate

OBSERVE THE SAFETY INSTRUCTIONS!

No additional fastening is required for jaw models plastered on a Multisplit mounting plate.

You can place the Multisplit mounting plate directly on the Multisplit base plate of the scanner. This option exists for the articulator systems AMANN GIRRBACH Artex® and Baumann Dental Artist/ArTO®.

- Plaster the jaw model onto the Multisplit mounting plate according to the manufacturer's instructions. Make sure to insert a magnetic adhesive disk into the Multisplit mounting plate.



- Place the Multisplit mounting plate on the Multisplit base plate of the scanner. Ensure that the protrusions ("Corners") on the underside of the Multisplit mounting plate fit into the recesses of the Multisplit base plate.

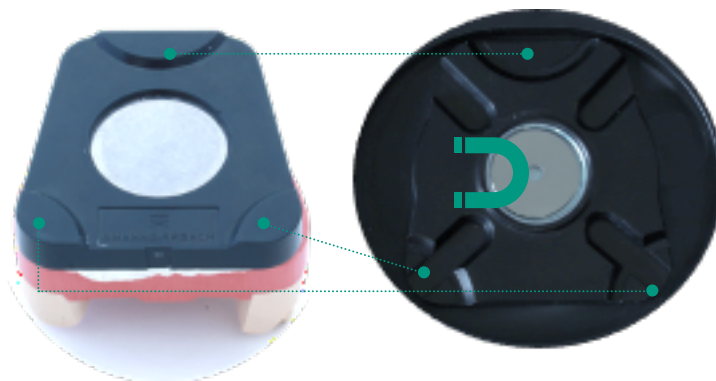

- ✓ The Multisplit mounting plate will adhere to the magnet of the Multisplit base plate.
- ✓ The Multisplit mounting plate fits correctly when the plates are exactly congruent. Additional securing of the plastered jaw model is not necessary.

7.2. Inserting a jaw model with an adaptor plate

OVERVIEW

Using an adaptor plate as spacer, you can place the mounting plates of articulated jaw models on the Multisplit base plate of the scanner.

Adaptor plates are available as optional accessories for the following articulator systems:



- SAM® AXIOSPLIT®
- GAMMA® Reference
- Whip Mix Denar®
- KaVo PROTAR®

No adaptor plates are required for AMANN GIRRBACH Artex® and Baumann Dental Artist/arTO®.

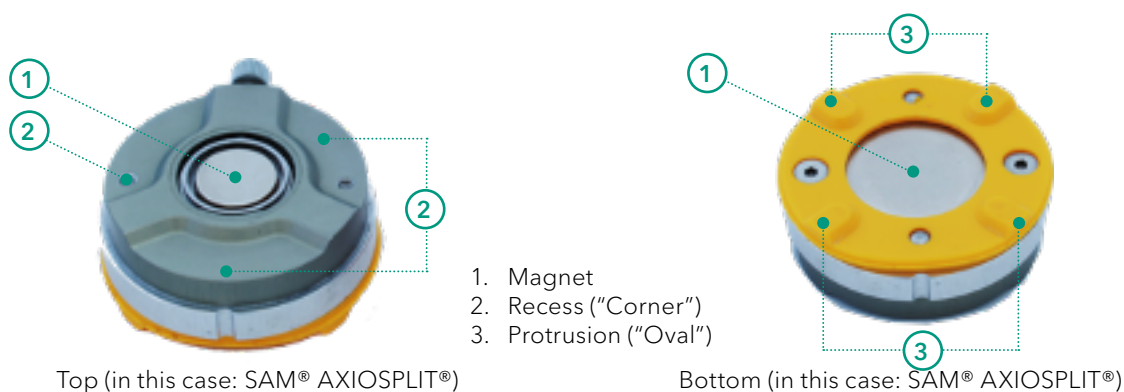

The mounting plates of the corresponding articulator fit the top of the adaptor plate. The underside fits to the Multisplit base plate inside the scanner.

PLACING A MOUNTING PLATE ON THE ADAPTOR PLATE

- Plaster the jaw model onto the mounting plate according to the manufacturer's instructions. Make sure to insert a magnetic adhesive disk into the mounting plate.

OBSERVE THE SAFETY INSTRUCTIONS!

- Place the mounting plate on the adaptor plate such, that the protrusions ("Corners") on the underside of the mounting plate fit into the identically shaped recesses of the adaptor plate.

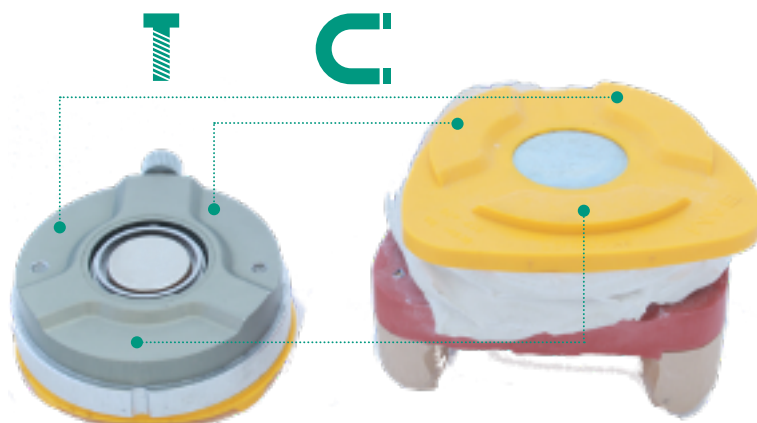

- ✓ The mounting plate will adhere to the magnet of the adaptor plate.
- ✓ The mounting plate fits correctly when the plates coincide exactly.

SAM® AXIOSPLIT®



- The magnetic adhesive disk in the adaptor plates for SAM® AXIOSPLIT® is retained with a fixating screw. Ensure that this is tightened firmly.

➤ Additional securing of the plastered jaw model is not necessary.

INSERTING AN ADAPTOR PLATE

OBSERVE THE SAFETY INSTRUCTIONS!

- Hold the adaptor plate from the side of the Adesso Split® plastic plate.
- Insert the adaptor plate into the scanner.

➤ The protrusions (“Ovals”) on the underside of the plastic plate engage with the recesses of the Multisplit base plate.

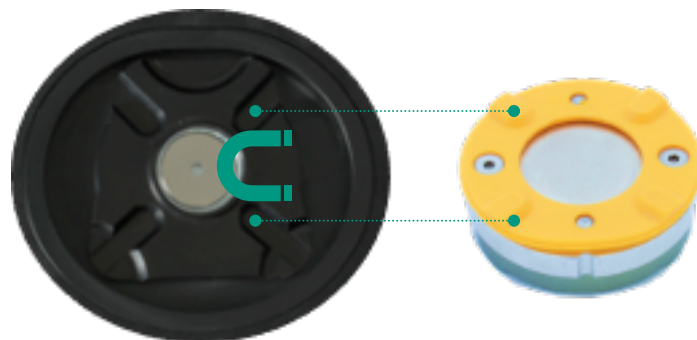

➤ The adaptor plate will adhere to the magnet of the Multisplit base plate.

- Check whether the adaptor plate can be shifted easily. If this is the case, correct the fit until the adaptor plate fits securely.

REMOVING THE ADAPTOR PLATE

- Hold the adaptor plate on two sides; if necessary, use both hands (not the mounting plate).



- Carefully pull the adaptor plate upwards. A certain amount of force is required due to the magnetic attraction.

➤ The adaptor plate is released from the Multisplit base plate.

The axes can be moved unintentionally during removal. For this situation, Aadva Scan features a function to drive the axes back into the service position.

7.3. Inserting a jaw model with an object holder

OVERVIEW

Object holder with screw

1. Rear
2. Front
3. Floating stop
4. Hook
5. Threaded pins
6. Knurled screw with clockwise thread
7. Adesso Split® plastic plate with adhesive disk

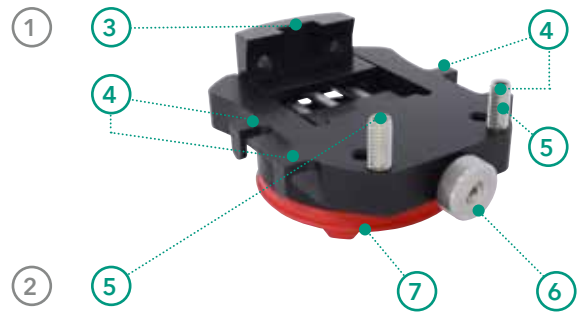

1. Front
2. Rear
3. Top
4. Magnetic points
5. Adesso Split® plastic plate with adhesive disk

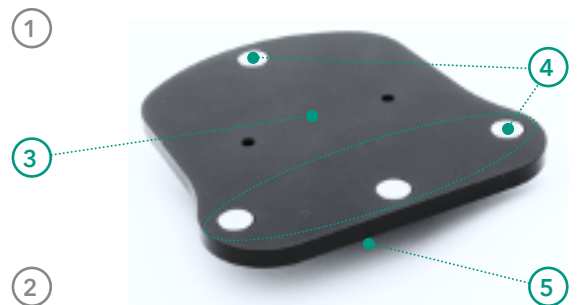

FASTENING A JAW MODEL ONTO AN OBJECT HOLDER

The object holders of the ALS 3 to fasten a jaw model mechanically. This method is to be applied to jaw models which are not plastered.

Object holder with screw

Different sizes of jaw models can be fastened securely to the object holder with the knurled screw.

OBSERVE THE SAFETY INSTRUCTIONS!

- Place the jaw model (upper or lower jaw) with the bottom side on the object holder.
 - If required, loosen the knurled screw to increase the space.
- The anterior teeth point in direction of the knurled screw.
- Press the jaw model gently against the threaded pins.
 - Tighten the knurled screw.
- The jaw model is placed correctly if it is flush with the floating stop and the threaded pins.



FLEXIBLE OBJECT HOLDER

Jaw models (upper or lower jaw) can be securely fastened on the flexible object holder with the big plate. To fasten them, you require adhesive glue pads.

Two packs of adhesive pads are included in the scope of delivery. You can purchase replacements from office suppliers if required.

- Cover the topside of the plate with adhesive pads. You should use at least three pads for complete jaw models.
- Place the jaw model (upper or lower jaw) with the bottom side on the adhesive pads.

/// The anterior teeth point in direction of the single magnetic point (1).

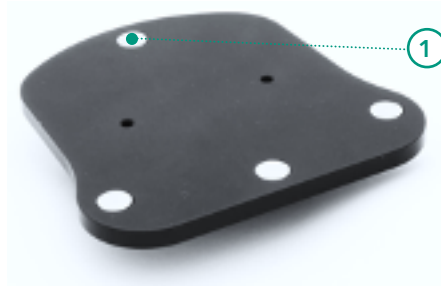

- Press the jaw model firmly.

/// The jaw model is placed correctly when it does not extend beyond the magnetic points.

- Tilt the object holder carefully to the right and left.

/// The jaw model is placed correctly when it does not slip.

- Should the jaw model slip, use additional adhesive pads.

INSERTING THE OBJECT HOLDERS

The described procedure is the same for both object holders.

OBSERVE THE SAFETY INSTRUCTIONS!

- Hold the object holder from the side.
- Place the object holder with the front side or the knurled screw facing forwards inside the scanner.

/// The protrusions ("Ovals") on the underside of the object holder engage with the recesses of the Multisplit base plate.

/// The object holder will adhere to the magnet of the Multisplit base plate.



- Check whether the object holder can be shifted easily. If this is the case, correct the fit until the object holder fits securely.

REMOVING THE OBJECT HOLDER

The described procedure is the same for both object holders. To fasten a jaw model to the object holder, you should always remove the object holder from the scanner.

- Hold the adaptor plate on both sides; if necessary, use both hands.
- Carefully pull the object holder upwards. A certain amount of force is required due to the magnetic attraction.

➤ The object holder is released from the Multisplit base plate.

Upon removal, the rotary axis may be moved unintentionally. For this situation, Aadvu Scan features a function to drive the axes back into the service position.

7.4. Fastening gingiva, squeeze bites, scanbodies or wax-ups



- To scan gingiva, squeeze bites, scanbodies or wax-ups, fasten the small prosthetic parts to the jaw model according to the prosthetics manufacturer's instructions.
- Tighten the scanbodies firmly.
- Fasten the prepared jaw model to an object holder or a mounting plate for your articulator.

➤ As a rule, no further fixation is required. Loosely placed parts can be glued slightly in two places with a removable adhesive if required.

8. Positioning of non-articulated occlusion models

You have various options for inserting an occlusion model into the scanner. The easiest method for non-articulated occlusion is to fasten the occlusion model to the object holder with knurled screw using a rubber band.

The flexible object holder is not suitable for this purpose.

Alternatively you can use an occlusion clamp.

For articulated occlusions you require an articulator.

8.1. Fastening an occlusion model with a rubber band

OBSERVE THE SAFETY INSTRUCTIONS!

To fasten the upper and lower jaw in occlusion, you require a conventional rubber band of approx. 0.4 cm width and approx. 8.5 cm diameter. Alternatively you can use a crossed band. The length and strength of the rubber band varies depending on the jaw model. For this reason, always keep several different rubber bands available.

Rubber bands are not included in the optional scanner accessories. For safety reasons, use only new, robust rubber bands and replace these regularly.

- Place the upper jaw model on the lower jaw model in occlusion.
- Place the rubber band in cross form so that the top part of the upper jaw model so that an equally long loop hangs from each side.
- Guide the end of each rubber loop around the hooks on the side of the object holder.



- The fastening is adequate if the upper jaw model cannot be tipped or shifted with slight pressure.

If necessary, shorten the rubber bands by coiling over the hooks several times.

Alternatively, you can use two shorter rubber bands or a crossed band. Depending on the length and strength of the rubber bands used, alternative fastening methods are possible, e.g.:

- Place two shorter rubber bands at an angle over the jaw model.
- Guide one end each at the front and rear around one of the hooks on the side of the object holder.

If you are using a crossed band, you can only secure the jaw models to the object holder in occlusion.

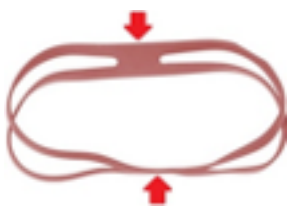

- Place the crossed band around the jaw models in occlusion such, that one crossed part is on the top and one on the bottom and that the two partial bands are stretched on the side.
- Secure the connected jaw models on the object holder.
- Guide the laterally stretched rubber bands around the hooks on the object holder.

8.2. Fastening of an occlusion model with an occlusion clamp

OBSERVE THE SAFETY INSTRUCTIONS!

With the aid of the GC occlusion clamps you can fasten the upper and lower jaw model easily and conveniently in non-articulated occlusion. The occlusion is closed in this manner and remains firmly joined, even during mechanical movement.

The occlusion clamp for non-articulated occlusion is an optional accessory for the ALS 3 and can be obtained from GC.

OVERVIEW

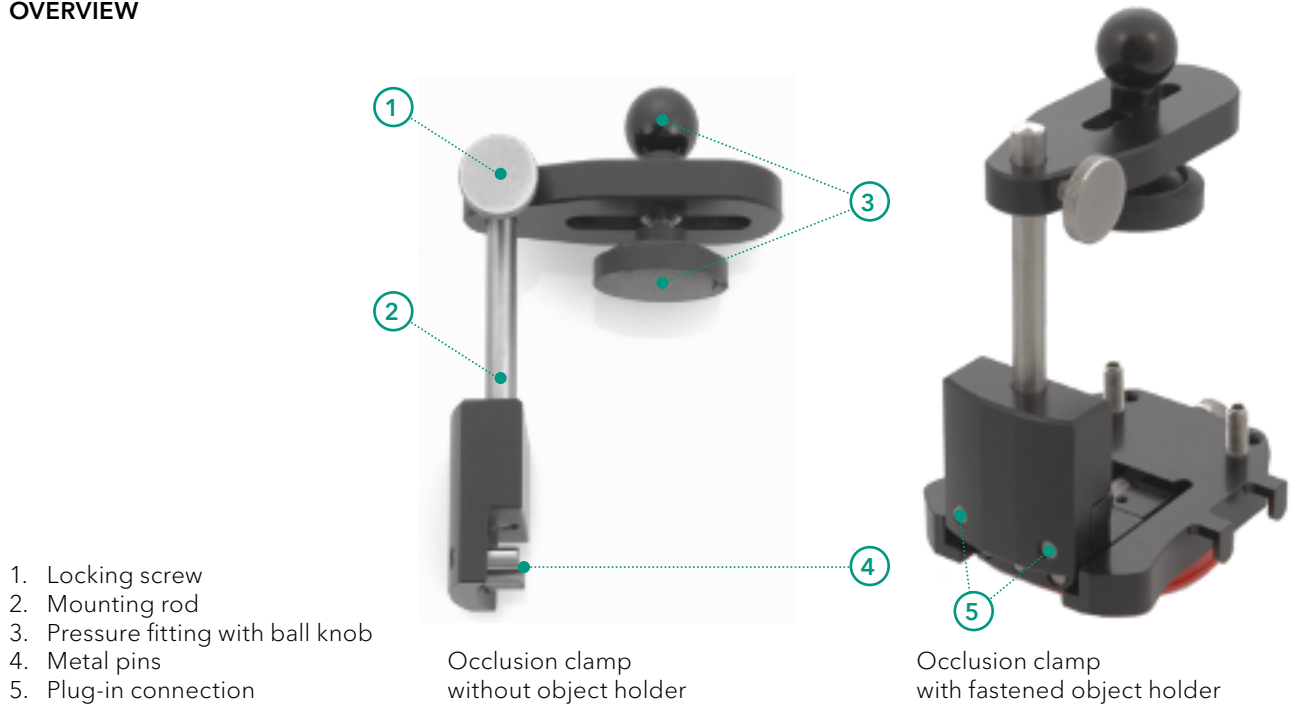

FASTENING

- Fasten first the lower jaw model to the object holder with the knurled screw.
 - Place the upper jaw model on the lower jaw model in occlusion.
 - Loosen the ball knob (3) as much as necessary to allow the pressure fitting to be moved forwards and backwards. Fasten the occlusion clamp to the floating stop of the object holder by pushing the metal pins (4) into the holes of the floating stop on the object holder (5).
 - Hold the occlusion model firmly.
 - Push the pressure fitting (3) on the ball knob as central as possible over the upper jaw model.
 - Loosen the locking screw (1) until the fastening rod (2) of the pressure fitting can be moved up and down.
 - Hold the ball knob and press the upper jaw model onto the lower jaw model.
 - Carefully tighten the screw (1) and the ball knob (3) until the occlusion model can no longer be moved.
- The occlusion model is clamped.
- Now place the object holder inside the scanner as usual.



9. Positioning of articulated occlusal models

With the help of an articulator, you can establish the articulated occlusion of the upper and the lower jaw model.

You can place any articulator without any further accessories inside the scanner for vestibular scans.

Condyle-related measuring is possible with the following articulators:

- AMANN GIRRBACH Artex® (without adaptor plate)
- Baumann Dental Artist/ArTO® (without adaptor plate)
- SAM® AXIOSPLIT®
- GAMMA® Reference
- Whip Mix Denar®
- KaVo PROTAR®

Articulators are available at specialist dealers, but not from GC as an accessory for the scanner.

9.1. Positioning of an occlusal model with an articulator

OVERVIEW

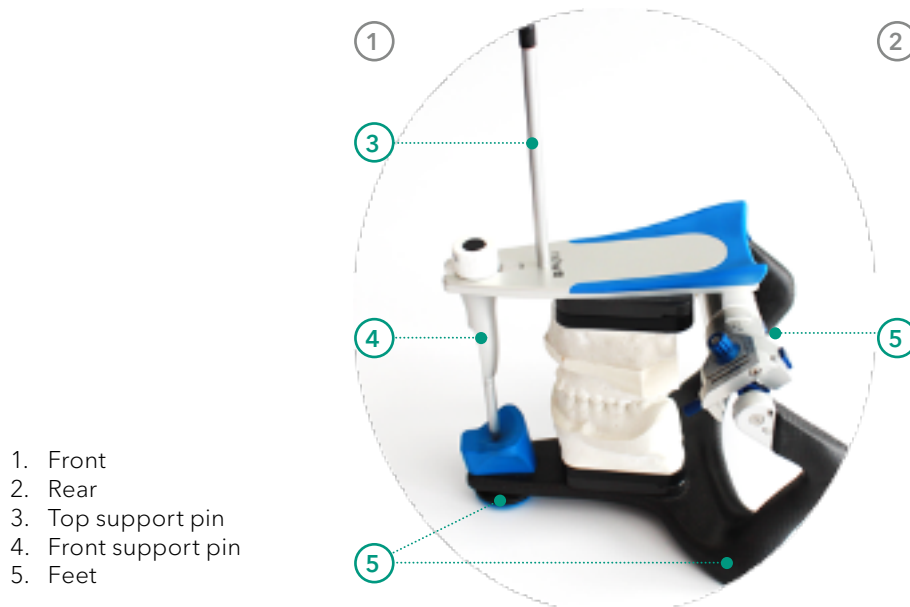

1. Front
2. Rear
3. Top support pin
4. Front support pin
5. Feet

INSERTING THE ARTICULATOR

ALS 3 allows easy placement of articulators by means of line projections on the base plate. Align the articulator with the illuminated lines onto the base plate.

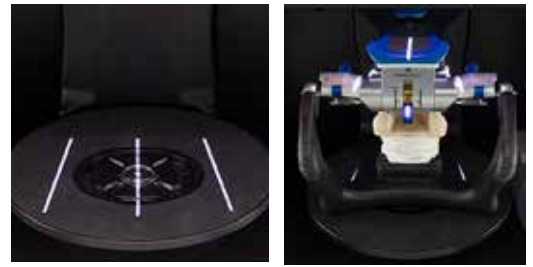

Example

AMANN GIRRBACH Artex®

All articulators are to be handled in the same way, independently of type and manufacturer.

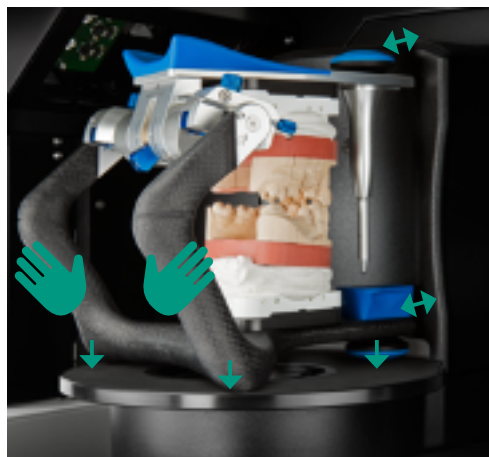

- Make sure that the occlusal model is correctly articulated.
- Remove the top support pin from the articulator.
- Also remove the front support pin, if possible.

OBSERVE THE SAFETY INSTRUCTIONS!

- It is essential that you wait until the software asks you to insert the articulator. Only then is it ensured that the motion of the axes is minimal during the ensuing scanning procedure.
- The system plate of the scanner is driven into the horizontal service position. If this is not the case, Aadvä Scan features a function allowing to drive to this position.
- Grasp the articulator by the rear struts with both hands.
- Place an articulator with the front side forward inside the scanner.
- The front side of the articulator points to the rear side of the scanner. A different orientation is not permitted.

Correct



False



- The articulator stands free and does not touch the scanner.
 - Place the articulator on the system plate so that all feet are resting on the rubber mat.
 - Place the articulator in a central position.
- The articulator stands centrally on the system plate. A different position is not permitted.
- The rubber mat is anti-slip. No further fastening is necessary.

REMOVING THE ARTICULATOR

- Wait until the software reports the end of the scanning procedure.
- Remove the articulator as soon as the software asks you to do so.
- Grasp the articulator as before by the rear struts.
- Lift the articulator horizontally out of the scanner.
- Now you can proceed with the workflow in the software.

Upon removal, the rotary axis may be moved unintentionally. For this situation, Aadva Scan features a function to drive the axes back into the service position.

10. Positioning tooth stump models with the multiDie adaptor

You can position up to twelve tooth stump models individually with the multiDie adaptor.

You can use the multiDie adaptor for the two modules multiDie and multiCase.

OVERVIEW



1. Adesso Split® plastic plate with adhesive disk
2. Slots
3. Flat side (front)

FASTENING TOOTH STUMP MODELS

To ensure that the tooth stump models sit firmly on the multiDie adaptor, you require the adhesive pads as fixing material.

As replacement you can use commercially available adhesive glue pads. These should be extra strong and removable, not coloring nor hardening.

- Fill all slots with adhesive pads.
- ▮ The glue material should fill the slots up to their edge, but not protrude from them. The glue material can remain in the slots permanently.
- Insert the metal pins of the tooth stump models into the slots.

Correct fastening

The prepared tooth stump models are fastened correctly if:

- they are straight (not tilted)
- they have no contact with their neighbor
- they lie on the multiDie adaptor - in other words, insert the metal pins as deep as possible into the glue material
- they remain in their position when the multiDie adaptor is rotated or tilted.

It is of advantage, but not a precondition, to insert the tooth stump models such that the buccal side faces outwards.

INSERTING THE MULTIDIE ADAPTOR



OBSERVE THE SAFETY INSTRUCTIONS!

- Hold the multiDie adaptor from the side.
- Place the multiDie adaptor inside the scanner so that the flat side faces the front of the scanner.
- // The protrusions (“Ovals”) on the underside engage with the recesses of the Multisplit base plate.
- // The multiDie adaptor will adhere to the magnet of the Multisplit base plate.
- Check whether the multiDie adaptor can be shifted easily.
If this is the case, correct the fit until the multiDie adaptor fits securely.

REMOVING THE MULTIDIE ADAPTOR

- Hold the multiDie adaptor from the side, if necessary, use both hands.
- Carefully pull the multiDie adaptor upwards.
A certain amount of force is required due to the magnetic attraction.
- // The multiDie adaptor is released from the Multisplit base plate.

Upon removal, the rotary axis may be moved unintentionally. For this situation, Aadv Scan features a function to drive the axes back into the service position.

11. Positioning of a Triple Tray impression

The Triple Tray impression holder allows you to position Triple Tray impression trays inside the scanner.

You can use the Triple Tray impression holder with the Triple Tray impression scan module.

OVERVIEW

1. Upper part
2. Lower part
3. Rear
4. Front
5. Magnetic adhesion point
6. Clamp with spring
7. Adesso Split® plastic plate with adhesive disk



FASTENING A TRIPLE TRAY IMPRESSION SCAN

OBSERVE THE SAFETY INSTRUCTIONS!

A Triple Tray impression tray can be clamped quite easily in the Triple Tray impression holder.

- Press the clamp on the broad side and keep it pressed.

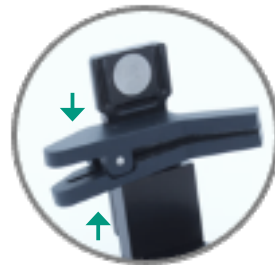

■ The opposite side is pressed apart.

- Turn the side of the Triple Tray impression demanded by the software upwards.
- Insert the flat shaft of the Triple Tray impression holder into the narrowest position between the open side of the clamp.
- Release the clamp.



CORRECT FASTENING

The Triple Tray impression is fastened correctly if:

- it is clamped
- it is positioned parallel to the lower part of the Triple Tray impression holder
- the impression to be scanned faces upwards.

TURNING A TRIPLE TRAY IMPRESSION

To scan the other side of the Triple Tray impression, turn the upper part without releasing the impression from the clamp.

- Separate the upper part from the lower part applying a little force.
- /// The magnetic contact is released.
- Turn the upper part so that the other side of the impression faces upwards.
 - Press the lower magnetic point against the lower part.

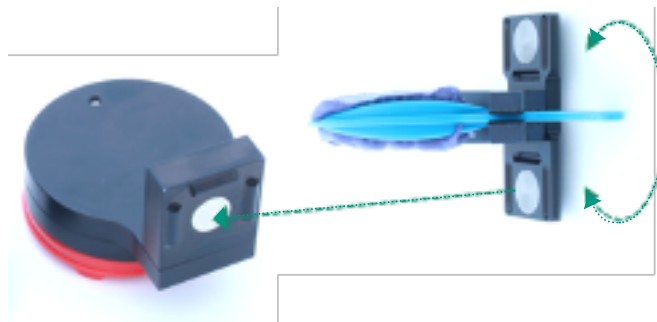

- /// The upper part will adhere magnetically to the lower part. The adhesive effect is reinforced by the grooves and braces.

INSERTING THE TRIPLE TRAY IMPRESSION HOLDER



- Hold the Triple Tray impression holder from the rear.
 - Place the Triple Tray impression holder with the impression facing forwards inside the scanner.
- /// The Triple Tray impression holder will adhere to the magnet of the Multisplit base plate.
- /// The protrusions ("Ovals") on the underside of the plastic plate engage with the recesses of the Multisplit base plate.
- /// The Triple Tray impression faces to the rear of the scanner.

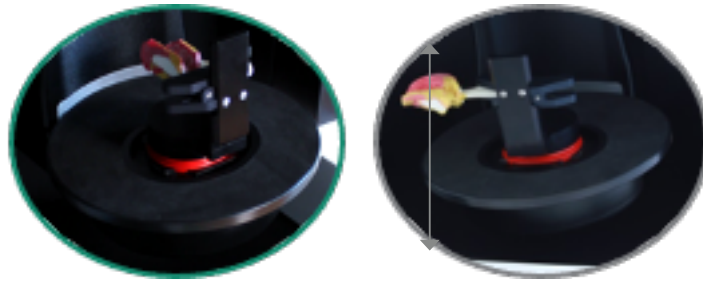

- Check whether the Triple Tray impression holder can be shifted easily. If this is the case, correct the fit until the Triple Tray impression holder is adhered securely.

REMOVING THE TRIPLE TRAY IMPRESSION HOLDER

- Hold the Triple Tray impression holder by the lower part; if necessary, use both hands.
- Carefully pull the Triple Tray impression holder upwards. A certain amount of force is required due to the magnetic attraction.

■ The Triple Tray impression holder is released from the Multisplit base plate.

Upon removal, the rotary axis may be moved unintentionally. For this situation, Aadva Scan features a function to drive the axes back into the service position.

12. Positioning objects (universal mode)

Scannable objects are very individual physical bodies. Thus, only general advice on correct positioning can be provided here. In principle, GC recommends using the flexible object holder for the Universal Mode.

FLEXIBLE OBJECT HOLDER

1. Front
2. Rear
3. Top
4. Magnetic points
5. Adesso Split® plastic plate with adhesive disk

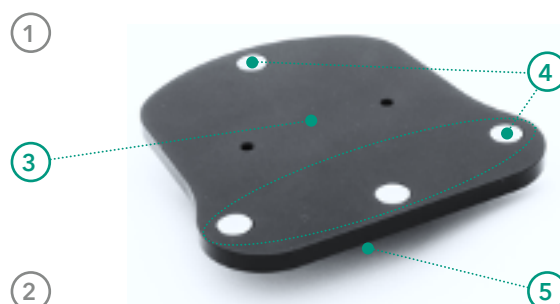

With this object holder, solid, opaque objects such as tools, jewelry or toys with a maximum size of 85,2 × 58,1 × 82 mm (XYZ) and a maximum weight of 0.938 kg can be scanned.

85,2 × 58,1 × 82 mm (XYZ)
0.938 kg

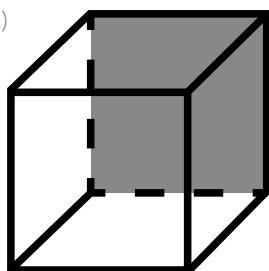

PROPERTIES OF SCANNABLE OBJECTS

Glossy surfaces (such as metal) or very dark surfaces cannot be scanned. Reflections and lack of contrast to the scanner's interior make an accurate measurement impossible. Therefore, such objects should be matted with 3D scan spray.

Dimensional stability

Only objects that do not change their shape during scanning can be scanned. Make sure that moving parts are adequately immobilized.

Top and bottom

To fully digitize a three-dimensional object, it usually needs to be scanned from two sides. The second scan captures the bearing surface that was hidden during the first scan. In the simplest case, turn the object on the object holder. Depending on the shape of the object, it may be useful to choose a different fastening for the second side.

12.1. Fastening objects on the flexible object holder

OBSERVE THE SAFETY INSTRUCTIONS!

Objects can be fastened securely on the flexible object holder with the big plate.

Try out the best way to fasten an object.

Test the stability of the fastening outside the scanner using sideways and rotational movements to determine which object holder best fits an object. Create sample scans and compare the results.

So you can, for example, place jewelry instead of single-tooth models into the multiDie adaptor or clamp them into the Triple Tray impression holder. The object holder with the knurled screw can achieve good results with solid bodies having a wide, smooth underside. Please note that multiDie adaptors and Triple Tray impression holders can only support smaller, lighter weight items (<85,2 x 58,1 x 82 mm (XYZ), 0.938 kg).

MAGNETIC OBJECTS

Four magnetic points are placed on the top of the object holder. Each of the magnets measures: 10.0 × 3.0 H mm. The adhesive force depends on the opposite pole and the environmental conditions and must therefore be checked on a case-by-case basis.

Magnetic points

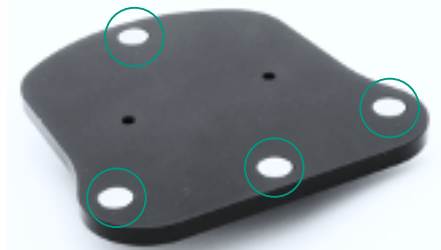

- Place a magnetic object on the plate so that it is held by the magnetic points.
 - If the object does not cover the area between the magnetic points, you can enlarge the area with magnetic plates or magnetic tape (available as office supplies).
- /// The adhesive effect depends on the individual magnetization of the object and the inserted magnetic plates.

NON-MAGNETIC OBJECTS

Adhesive glue pads are necessary to fasten non-magnetic objects. Two packs of adhesive pads are included in the scope of delivery. You can purchase replacements from office suppliers if required.

- Cover the topside of the plate with adhesive pads. Different numbers of adhesive pads may be needed, depending on the size, weight and shape of the object. Knead several adhesive pads together and shape e.g. a plate or a pillow.
- Place the object with the underside on the adhesive pads.
- Align the front / main side of the object with the single magnetic point (1).

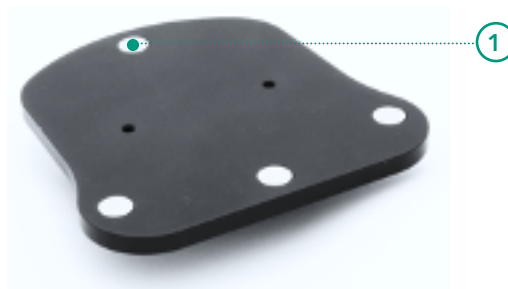

- Press the object firmly.
- /// The object is placed properly if it does not protrude beyond the magnetic points.
- Tilt the object holder carefully to the right and left.
- /// The object is placed correctly when it does not slip.
- If the object does slip, use more adhesive pads or alternatively test another object holder.

12.2. Inserting the object holder

The described procedure is the same for all object holders.

OBSERVE THE SAFETY INSTRUCTIONS!

- Hold the object holder from the side.
 - Place an object holder with the front side forward inside the scanner.
- /// The protrusions ("Ovals") on the underside of the object holder engage with the recesses of the Multisplit base plate.
- /// The object holder will adhere to the magnet of the Multisplit base plate.



- Check whether the object holder can be shifted easily. If this is the case, correct the fit until the object holder fits securely.

12.3. Removing the object holder

The described procedure is the same for all object holders. To fasten an object to the object holder, you should always remove the object holder from the scanner.

- Hold the adaptor plate on both sides; if necessary, use both hands.
 - Carefully pull the object holder upwards. A certain amount of force is required due to the magnetic attraction.
- /// The object holder is released from the Multisplit base plate.

Upon removal, the rotary axis may be moved unintentionally. For this situation, Aadv Scan features a function to drive the axes back into the service position.

13. Positioning the calibration model

A calibration model is required to calibrate the scanner. A calibration model is included in the scope of delivery. Each calibration model is measured industrially and assigned these measurements.

If your calibration model is damaged and you are unsure whether this model can be used, GC will be pleased to advise you and provide you with a replacement if necessary. It is recommended to have the calibration model always at hand during operation.

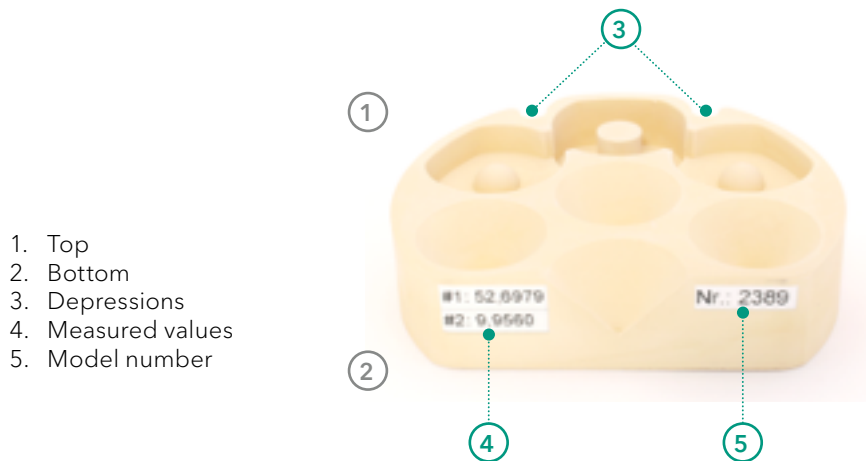

INSERTING AND REMOVING THE CALIBRATION MODEL

The calibration model is to be handled in the same manner as a single jaw model. To fasten it, you require the object holder with the knurled screw.

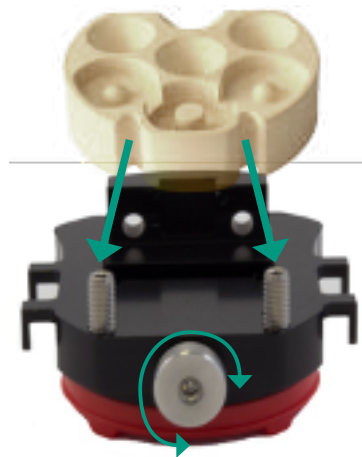

OBSERVE THE SAFETY INSTRUCTIONS!

- If required, loosen the knurled screw to provide more room on the object holder.
 - Place the underside of the calibration model on the object holder.
 - Press the depressions of the calibration model slightly against the threaded pins of the object holder.
 - Tighten the knurled screw.
- /// The calibration model is placed correctly when it is flush both at the front and the rear.
- /// The impression with the measured values faces the floating stop.
- Insert the object holder. When doing it, observe the software's messages.
 - Remove the object holder as usual.

14. Operating principle of the scanner

The most important components of the scanner are the 3D sensor and a positioning mechanism.

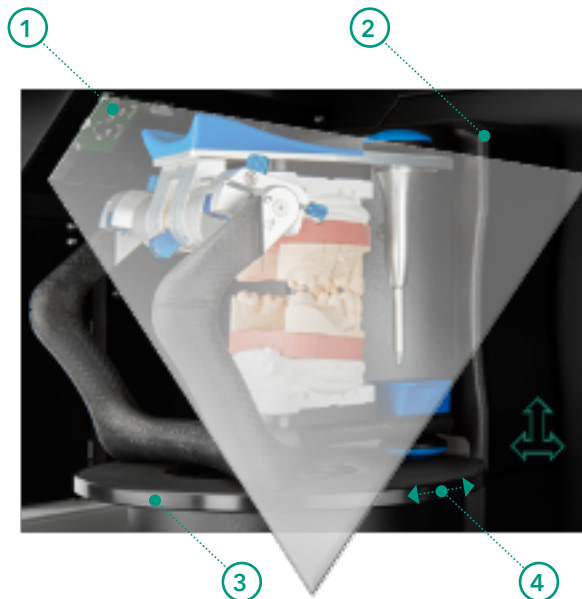

The positioning mechanism in the interior of the scanner consist of a rotary and swivel axis driven by an electric motor (4) as well as an automatic z-axis (2).

The freely rotating Multisplit base plate (3) positions the object to be measured with regard to the 3D sensor (1), which is located above the swivel axis.



The swivel axis moves the rotary axis with the object holder to the side so that the 3D sensor can capture the object to be measured from the side. During a measurement, the 3D sensor projects a striped pattern onto the object being scanned.

The light stripes are generated with a white or blue LED light. A blue LED light is used in combination with a 5 Mpx camera, as it requires more brightness and sharper contrasts.

The camera records the striped pattern. With the aid of several camera images taken from different angles, Aadv Scan calculates a 3-dimensional image of the object.

14.1. Operation via gesture control



The ALS 3 scanner can be partially operated via projections and gesture control. You can select scan icons and start scans with one finger.

PROCEDURE

The ALS 3 will project simultaneously up to three scan tab icons onto the scan plate. Next to the scan tab icons, arrows appear to scroll to the right or left to show hidden icons.

- Scroll the icons by holding a finger over the arrow. Your finger does not have to touch the system plate.

- The desired scan icon should be in the white circle. Activate the scan icon by holding your finger above the icon. An animation will show the activation and the scan icon will disappear.
- Position the scan object.
- Z-axis is automatically determined.
- Activate the start button to start the scan.



SCAN ICONS

- A white circle marks a selected scan icon.
- A red circle marks a non-selected scan icon.
- When two scan icons are shown, both can be selected.
- When three scan icons are shown, only the middle one can be selected.
- Left < and right > arrows can be used to scroll the scan icons.
- When a scan icon is selected, an animation will be shown. The scan icon will then disappear.
- A play button ▶ will appear. When the scan object is positioned, press the play button to start the scan

14.2 Die projections

14.2.1 DIE PROJECTIONS AFTER THE 2D SCAN

A 2D scan is a black and white photo of the model seen from above. The 2D scan is used to mark and define the exact position and indication of all teeth in AadvaScan.



On the model each tooth position is now illuminated by coloured projections marking the predefined indications. The size of the projections can be adjusted in the AadvaScan software.



14.2.2 DIE PROJECTIONS DURING THE SCANNING PROCESS

During the scanning process, red and green projections show which segments need to be inserted or removed.

- /// Green dot: these segments remain in the die model during scanning.
- /// Red dot: these segments must be removed during scanning.

14.3. Switching between LR and HR mode

The software allows you to switch between the low-resolution mode and the high-resolution mode. This determines the level of detail of the subsequent measurements. Please note that very detailed measurements take longer. If this is not required for the current project, you can save time with the low-resolution mode.

Whether high or low resolution should be default is determined in the settings of Aadv Scan. However, you can switch between the modes for each project and every single scan.

15. Device maintenance

The scanner is a delicate and sensitive optical device. To ensure trouble-free operation of the scanner, it is necessary to regularly follow the correct care measures.

Further maintenance measures by the user are not required.

SCANNER CALIBRATION

The scanner is calibrated with the aid of the software. This procedure is necessary to ensure accurate measurements.

Perform the calibration of the scanner after the first setup, every time after transporting it and whenever the software asks you to do so during operation.

CLEANING THE SCANNER

OBSERVE THE SAFETY INSTRUCTIONS!

The scanner should be cleaned regularly during operation. However, never clean the optical or other electronic components.

If the optical or electronic components are soiled, please contact GC .

Before cleaning

- Switch off the scanner for safety reasons.
- Remove the cable connections.
- Remove the object holder.

Materials

- Use microfiber cloths which are expressly suitable for high-gloss surfaces. The material must be soft, smooth, lint-free and anti-static.
- Always dampen the cleaning cloth with a glass cleaner.
- Never clean sensitive surfaces with abrasives, polishing pastes or rough cloths.

Cleaning

- Clean the surfaces as well as the object holder, the system plate and the axes with the moistened cleaning cloth.
- Clean the touchscreen without applying pressure.
- Coarse dirt and debris can be removed from the scanner floor with a vacuum cleaner. Attach the crevice nozzle and set the vacuum cleaner to its lowest vacuuming level.

16. Faults and repairs

If a fault occurs, first follow the safety instructions concerning response to a defect. If the fault persists, contact GC to clarify the cause of the fault.

Only have repairs carried out by GC.

WARRANTY

GC accepts no liability for damages caused by improper repairs. Please note that in this case your warranty claim will also become void.

SERIAL NUMBERS

If you have questions or complaints relating to your device, please have the serial number of your Scanner and the serial number of the 3D sensor at hand.

You will find these numbers on the rear of the device:

TYPE PLATE

Serial number of the scanner



LABEL

Serial number of the 3D sensor



17. Environmentally-friendly disposal

The information in this chapter refers to EU directives.

In non-European countries you must follow the corresponding national legislation for the disposal of packaging and electronic scrap.

You can prevent negative consequences for people and avoid harming the environment by the proper disposal of the device.

17.1. Disposal of the packaging

In accordance with the EU Directive 94/62/EC | 2015/720/EU, you can return the packaging to GC for disposal. However, GC recommends that you keep the packaging in case you need it to transport the scanner or to send it back in the event of warranty claims.

17.2. Disposal of the device

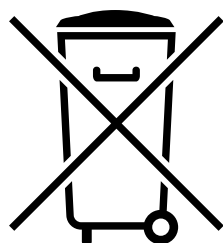

The devices marked with this symbol are subject to European Directive 2002/96/EC for WEEE (Waste Electrical and Electronic Equipment).
WEEE registration number of the manufacturer:
DE47893210

Electrical equipment must not be disposed of with domestic waste.

Please note that the scanner is a device that only serves for commercial or industrial use. Disposal via public waste management authorities is therefore not possible.

The device must be returned to the manufacturer for disposal. If you are resident within the area in which the EU directive applies you can also return the device to GC.

18. Technical specifications

| ALS 3 | |
|--|--|
| First production | 2019 |
| Last hardware update | 2023 |
| Housing | |
| Dimensions W × H × D mm | 455 × 430 × 435 mm |
| Weight | 23 kg |
| Maximum load-bearing capacity (Universal Mode) | 0.938 kg |
| Axes | 1 Rotary axis 1 Swivel axis 1 Z-axis |
| Material | Metal (anodized), plastic (ABS HB PMMA) |
| Housing color | black |
| ON/OFF switch | Toggle switch, rear |
| E-technology | |
| Supply voltage | 100 - 240 V AC 50/60 Hz |
| Fuse | 2 × T 1.6 A L 250 V |
| Power consumption | max. 60 W |
| Connections | 1 × USB 3.0 1 × power |
| Cables & plugs USB 3.0 | 1.8 m A/B (high performance) 2.5 m AC 110/230 V E+F CEE 7/7 |
| Temperature | |
| Operation | 18°C - 30°C |
| Storage | -5°C - 50°C |
| Measurement | |
| High-resolution camera | Yes |
| HR Mode resolution | 3.2 / 6.4 * |
| LR Mode resolution | 1.6 / 3.2 * |
| Camera | Point Grey |
| 3D measuring technology | Stripe light triangulation with diffused blue light LED |
| Measuring field XYZ mm max. object size in the universal mode | 85,2 × 58,1 × 82 |
| Measuring accuracy According to ISO 12836 | 4 μm |
| PC (recommended) | CPU: i7 with 6 × 4.7 GHz 32 GB RAM Port: USB 3.0 HDD SSD: 100-250 GB Graphics card RAM: 6 MB |
| Operating system (Minimum) | Windows 10 (64-Bit) |
| Operating system (recommended) | Windows 10 (64-Bit) |
| CAD-Software | AadvCad DentalCAD (all versions) |

*The DUAL Sensor can be switched between quantity and resolution of cameras (1 or 2 cameras in Low Res or 1 or 2 cameras in High Res)

19. Glossary

| | |
|------------------------|---|
| 3D scan | Three-dimensional image of the model in the software. |
| 3D sensor | Electronic component for three-dimensional measurement. The 3D sensor is not movable. |
| Articulator | Dental tool for fabricating a condyle-related occlusion. Articulators are available from various manufacturers. The most common articulators can be scanned condyle-related with the ALS 3. |
| Blue light/white light | LED light used for measurements. |
| Calibration | A metrological term. A) alignment of the scanner to the values of an industrially calibrated model. B) alignment of the motion axes with regard to the individual calibration data. |
| Calibration model | Industrially measured model which is used for calibrating the scanner. |
| Height alignment | Positioning of the model in the measuring field of the 3D sensor with the aid of the z-axis. |
| HR mode | High-resolution scanning. |
| Lens | Optical component of the camera. |
| Measurement | Calculation of the surface which can be measured through the projection of stripe light. Triangulation is the measuring principle. |
| Measuring field | Size of the maximum area which can be captured by the 3D sensor. |
| Model | A model which is scanned, e.g. the impression of a plaster jaw. |
| Multisplit base plate | Permanently mounted magnetic plate onto which the Multisplit mounting plates, object holders and adaptor plates can be fastened. |
| Object holder | A holder on which the object to be measured (e.g. jaw model) is mounted and which itself is then mounted to the base in the scanner. |
| Occlusion clamp | Special holder with which a non-articulated jaw model is placed inside the scanner. The occlusion clamp is used for easy fastening of occlusion models. |
| Rotary axis | One of the motion axes of the scanner. The base can be rotated. Free rotation of the base allows full circumferential positioning in front of the camera. |
| Stripe light | A striped pattern which is projected on the model to measure the surface three-dimensionally. |
| Swivel axis | One of the motion axes of the scanner. The swivel axis moves sideways so that the model is positioned in front of the camera at different angles. The swivel axis carries the rotary axis. |
| Triangulation | Measuring method for determining the position of a point in space with the help of triangles. |
| Universal Mode | Use of the scanner for non-dental purposes. |
| Z-axis | One of the motion axes of the scanner. The z-axis moves up and down so that the model is positioned in front of the camera at different heights. |

Technical Specifications

Measurement field (X × Y × Z) mm

85,2 × 58,1 × 82

2 x 3.2 Camera

4 µm Accuracy according to ISO 12836

Blue light LED sensor technology

Stripe light triangulation

Diffused blue light LED

Monochrome texture scan

Colour texture scan

Fully automated Z-axis

Articulator scan

multiDie scan

TripleTray scan

Impression scan

Recommended computer specifications

ALS 3 and Aadv Scan:

Windows 10 64-bit

i7 with 6× 4.7 GHz

32 GB RAM

USB 3.0 Port

100 – 250 GB SSD

Graphics card with 6 GB RAM



GC EUROPE N.V.

Head Office

Researchpark

Haasrode-Leuven 1240

Interleuvenlaan 33

B-3001 Leuven

Tel. +32.16.74.10.00

Fax. +32.16.40.48.32

info.gce@gc.dental

www.gc.dental/europe

GC UNITED KINGDOM Ltd.

Coopers Court

Newport Pagnell

UK-Bucks. MK16 8JS

Tel. +44.1908.218.999

Fax. +44.1908.218.900

info.uk@gc.dental

www.gc.dental/europe/en-GB